

# DEBIX I/O Board User Guide

Version: V1.1 (2024-12)

Compiled by: Polyhex Technology Company Limited (<http://www.polyhex.net/>)

DEBIX I/O Board is an add-on board designed for DEBIX Model A and DEBIX Model B SBC, and is compatible with DEBIX Infinity and DEBIX R series R3576-01. It adds one Gigabit network interface and POE capability to DEBIX single board computers. It comes with RS232, RS485 and CAN Transceiver to allow connection with more industrial equipment, and its strong expansion ability brings unlimited possibilities.



Figure 1 DEBIX I/O Board

## REVISION HISTORY

Rev.	Date	Description
1.0	2023.07.21	First edition
1.1	2024.12.25	Added compatibility with DEBIX R series R3576-01

---

**INDEX**

Chapter 1 Security .....	5
1.1. Safety Precaution .....	5
1.2. Safety Instruction .....	5
1.3. Declaration of Compliance .....	6
1.4. Technical Support .....	7
Chapter 2 DEBIX I/O board Introduction .....	8
2.1. Overview .....	9
2.2. Interface .....	11
2.2.1. Ethernet Interface .....	11
2.2.2. Debug Interface .....	11
2.2.3. RS485/RS232/CAN .....	12
2.2.4. POE Interface .....	14
2.2.5. GPIO Interface .....	14
2.2.6. MIPI DSI .....	16
2.2.7. MIPI CSI .....	17
2.2.8. DIP Switch .....	17
2.2.9. RTC .....	19
2.3. Packing List .....	19
Chapter 3 Getting started .....	20
3.1. Hardware connection .....	20
Chapter 4 Function Examples .....	25
4.1. Ubuntu Desktop Setting .....	25
4.2. Usage of Ethernet .....	28
4.3. Usage of Type-C Debug .....	28
4.4. Usage of Camera .....	31
4.5. Usage of DSI Display .....	34
4.6. Verification of CAN/RS485/RS232 .....	37



4.5.1. CAN .....	37
4.5.2. RS485 .....	39
4.5.3. RS232 .....	41
4.7. Verification of RTC .....	42
4.8. Usage of Raspberry Pi POE HAT .....	44

# Chapter 1 Security

## 1.1. Safety Precaution

The following messages inform how to make each cable connection. In most cases, you will simply need to connect a standard cable.

**Table 1 Terms and conventions**

Symbol	Meaning
<p><i>Warning!</i></p> 	<p>Always disconnect the power cord from the chassis whenever there is no workload required on it. Do not connect the power cable while the power is on. A sudden rush of power can damage sensitive electronic components. Only experienced electricians should open the chassis.</p>
<p><i>Caution!</i></p> 	<p>Always ground yourself to remove any static electric charge before touching <i>DEBIX</i> product. Modern electronic devices are very sensitive to electric charges. Use a grounding wrist strap at all times. Place all electronic components on a static-dissipative surface or in a static-shielded bag.</p>

## 1.2. Safety Instruction

To avoid malfunction or damage to this product please observe the following:

1. Disconnect the device from the DC power supply before cleaning. Use a damp cloth. Do not use liquid detergents or spray-on detergents.
2. Keep the device away from moisture.
3. During installation, set the device down on a reliable surface. Drops and bumps will lead to damage.
4. Before connecting the power supply, ensure that the voltage is in the required range, and the way of wiring is correct.
5. Carefully put the power cable in place to avoid stepping on it.
6. If the device is not used for a long time, power it off to avoid damage caused by sudden

overvoltage.

7. Do not pour liquid into the venting holes of the enclosure, as this could cause fire or electric shock.

8. For safety reasons, the device can only be disassembled by professional personnel.

9. If one of the following situations occur, get the equipment checked by service personnel:

- The power cord or plug is damaged.
- Liquid has penetrated into the equipment.
- The equipment has been exposed to moisture.
- The equipment does not work well, or you cannot get it to work according to the user's manual.
- The equipment has been dropped and damaged.
- The equipment has obvious signs of breakage.

10. Do not place the device outside the specified ambient temperature range. This will damage the machine. It needs to be kept in an environment at controlled temperature.



11. Due to the sensitive nature of the equipment, it must be stored in a restricted access location, only accessible by qualified engineer.



**DISCLAIMER:** Polyhex disclaims all responsibility for the accuracy of any statement of this instructional document.

### 1.3. Declaration of Compliance

This product has passed the following certifications:

**Table 2 Compliance Certification**

Symbol	Meaning
	This equipment has passed CE certified.
	This equipment is manufactured in compliance with RoHS regulations.

	This equipment has passed UKCA certified.
	This equipment has passed FCC certified.

## 1.4. Technical Support

1. Visit DEBIX website <https://www.debix.io/> where you can find the latest information about the product.
2. Contact your distributor, sales representative or Polyhex's customer service center for technical support if you need additional assistance. Please have the following info ready before you call:
  - Product name
  - Description of your peripheral attachments
  - Description of your software(operating system, version, application software, etc.)
  - A complete description of the problem
  - The exact wording of any error messages

**Discord Community (recommended):** <https://discord.com/invite/adaHHaDkH2>

**Email:** [info@debix.io](mailto:info@debix.io)

---

## Chapter 2 DEBIX I/O Board Introduction

DEBIX I/O board expands I/O interfaces of the DEBIX motherboard, for example, Gigabit Ethernet, RS232, RS485, CAN etc., which can be compatible with Raspberry Pi's peripherals, and it is more convenient to communicate with industrial equipment.

Main Features:

- Compatible with Raspberry Pi's camera and official 7" display.
- Expand I/O interfaces of DEBIX.
- Add a Gigabit Ethernet port and POE function.



## 2.1. Overview

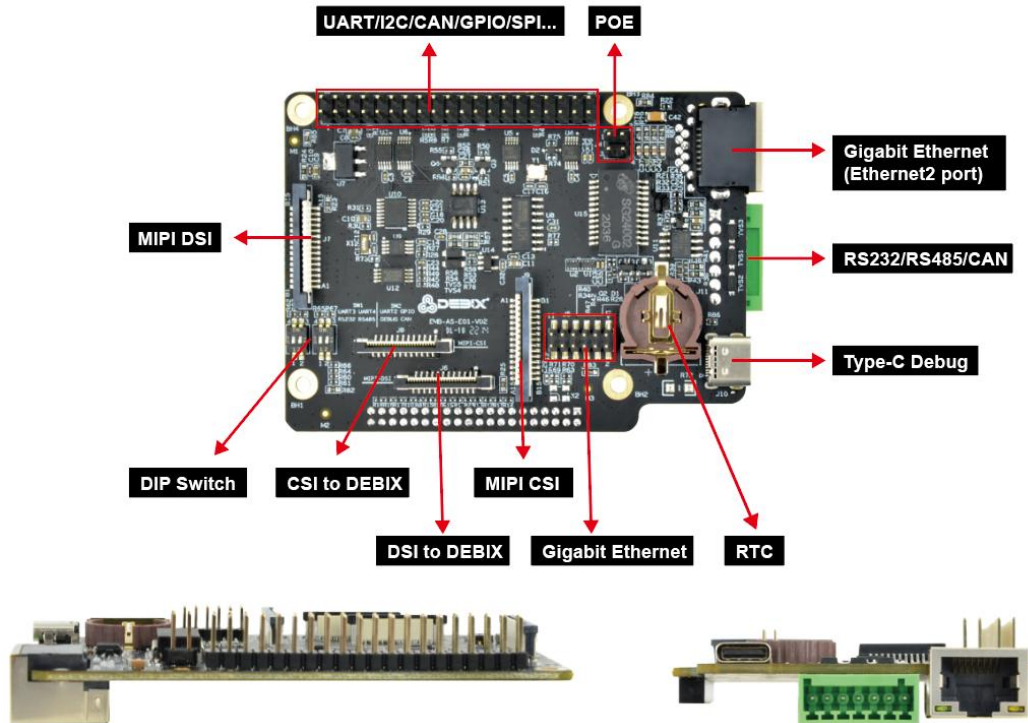

Figure 2 DEBIX I/O Board

DEBIX I/O board expands the I/O interface of DEBIX motherboard to support Gigabit Ethernet, POE, etc. The data specifications are as below:

Table 3 DEBIX I/O Board specification

Communication	
Gigabit Network	<ul style="list-style-type: none"> <li>● 1 x Gigabit Ethernet port</li> <li>● 1 x Gigabit Ethernet with 12pin header port (without network transformer), connects to the 12pin header Gigabit Ethernet port of DEBIX motherboard</li> </ul>
Video	
MIPI CSI	1 x MIPI CSI, support 4-lane, 30Pin 1.0mm Pitch FPC socket
CSI to DEBIX	1 x MIPI CSI, support 4-lane, 24Pin 0.5mm Pitch FPC socket, connects to the CSI interface of DEBIX motherboard

MIPI DSI	1 x MIPI DSI, support 4-lane, 30Pin 1.0mm Pitch FPC socket
DSI to DEBIX	1 x MIPI DSI, support 4-lane, 24Pin 0.5mm Pitch FPC socket, connects to the DSI interface of DEBIX motherboard
<b>External I/O Interface</b>	
USB	1 x USB Type-C Debug (USB to Serial)
UART	1 x RS232/RS485/CAN
RTC	1 x RTC
40-Pin Double-Row Headers	<ul style="list-style-type: none"> <li>● Default: 3 x UART, 2 x SPI, 2 x I2C, 2 x CAN, 6 x GPIO, refer to <a href="#">DEBIX website</a> "DEBIX Model A Reduced GPIO Function List", which can be configured to I2S, PWM, SPDIF, GPIO, etc. via software</li> <li>● 5V power supply, system reset, ON/OFF</li> </ul>
POE	1 x 4pin header
DIP Switch	2 x 2bit DIP Switch (to select USB-Debug, RS232, RS485, CAN)
Storage	2Kbit EEPROM
<b>Power Supply</b>	
Power Input	DC 5V/500mA
<b>Mechanical &amp; Environmental</b>	
Size (L x W)	85.0mm x 61.2mm (±0.5mm)
Weight	62g (±0.5g)

## 2.2. Interface

### 2.2.1. Ethernet Interface

DEBIX I/O Board provides two Ethernet interfaces, one is MAC Gigabit Ethernet port and one is 12pin header Gigabit Ethernet port.

- One independent MAC Gigabit Ethernet port (J3) , and a set of status indicators below the interface to display the status signal, one is Link (Green), network connection indicator and the other is Active (Yellow), signal transmission indicator.
- One Gigabit Ethernet with 2 x 6Pin header port (J5) for connecting to the 12pin header Gigabit Ethernet port (J6) of DEBIX motherboard.

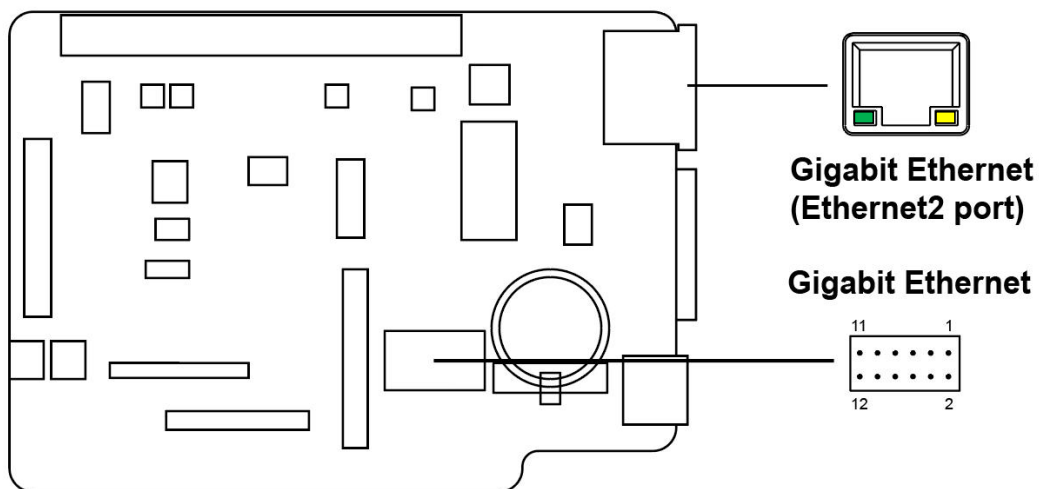

Figure 3 Ethernet Interface

### 2.2.2. Debug Interface

DEBIX I/O board provides a USB Type-C Debug interface (J10) as a debug port for DEBIX troubleshooting program.

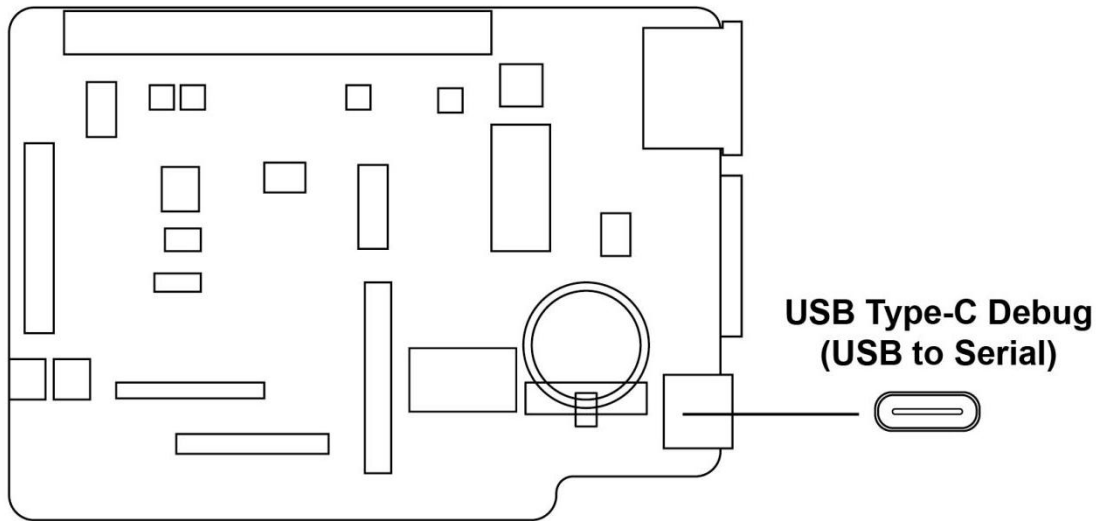

Figure 4 Debug interface

### 2.2.3. RS485/RS232/CAN

DEBIX I/O board provides a green RS232/RS485/CAN interface (J12) with a standard industrial communication connector, its model is KF2EDGR-2P5\_7P.

For the specification of RS232/RS485/CAN connector, please refer to "RS232/RS485/CAN Connector Specification" of [DEBIX I/O Board](#) to match its connector as required.

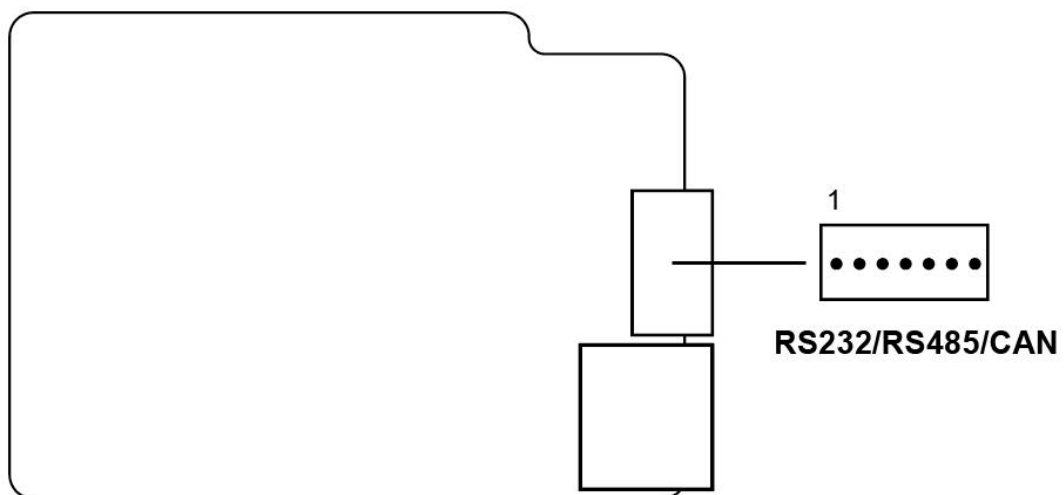

Figure 5 RS232/RS485/CAN

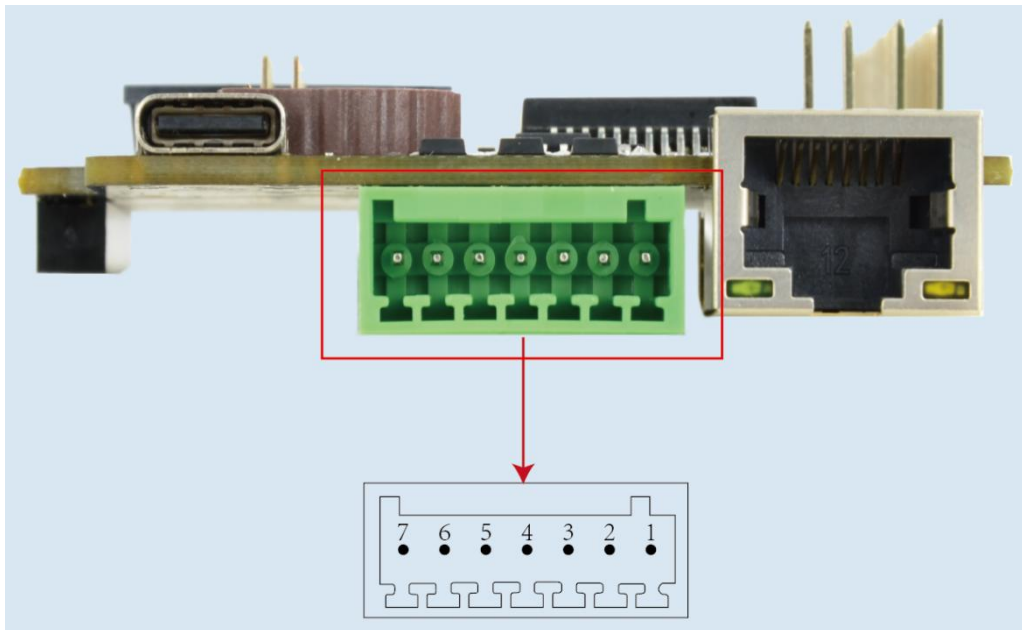

Figure 6 Pin sequence of RS232/RS485/CAN

The RS232/RS485/CAN interface definitions, and device nodes are listed in the table below:

**Table 4 Pin definition of RS232/RS485/CAN**

Pin	Definition	Pin	Definition
1	CAN1_H	2	CAN1_L
3	RS485_A	4	RS485_B
5	UART3-RXD	6	UART3-TXD
7	GND		

**Table 5 Device node of RS232/RS485/CAN**

Function name	I/O name	Device node	Description
CAN	CAN1_H	can0	HIGH-level CAN bus line
	CAN1_L		LOW-level CAN bus line
RS485	RS485_A	/dev/ttyxc3	Noninverting Receiver input and Driver Output
	RS485_B		Inverting Receiver Input and Driver Output
RS232	UART3-RXD	/dev/ttyxc2	DEBIX serial port receive
	UART3-TXD		DEBIX serial port send

## 2.2.4. POE Interface

DEBIX I/O Board provides one 4-pin header POE interface (J4) for POE power supply when needed.

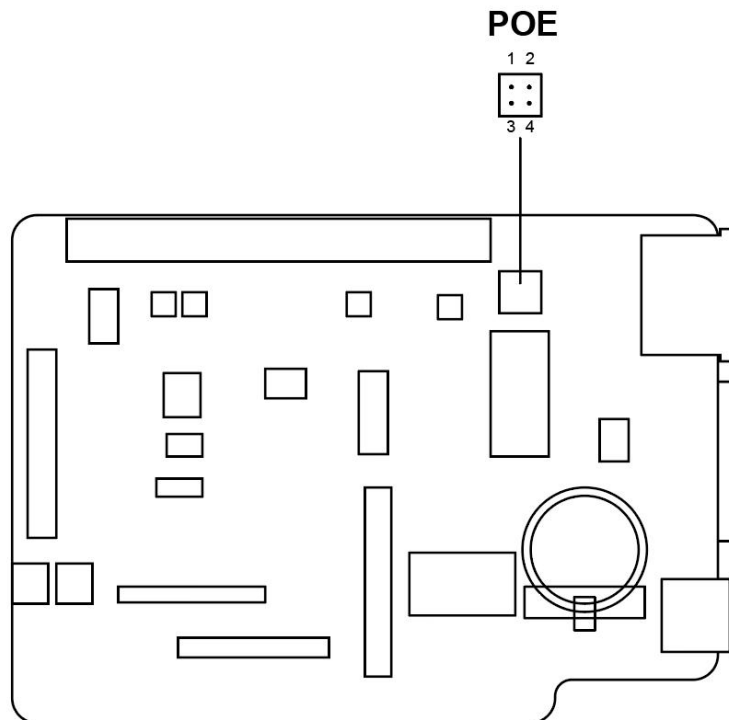

Figure 7 POE interface

## 2.2.5. GPIO Interface

DEBIX I/O board has a set of 2\*20Pin/2.0mm GPIO interface (J2), which extends the RS232, RS485, CAN and other interfaces of DEBIX motherboard, and can also be used for external hardware such as LED, button, sensor, function modules, etc.

- The voltage of I2C, UART, CAN, SPI, GPIO pin is 3.3V, the CAN pin needs to be used in conjunction with a CAN transceiver peripheral for CAN communication.
- 5V pins (pin2, pin4) can be used to power to DEBIX Model A/B, DEBIX Infinity, R3576-01 or peripherals.

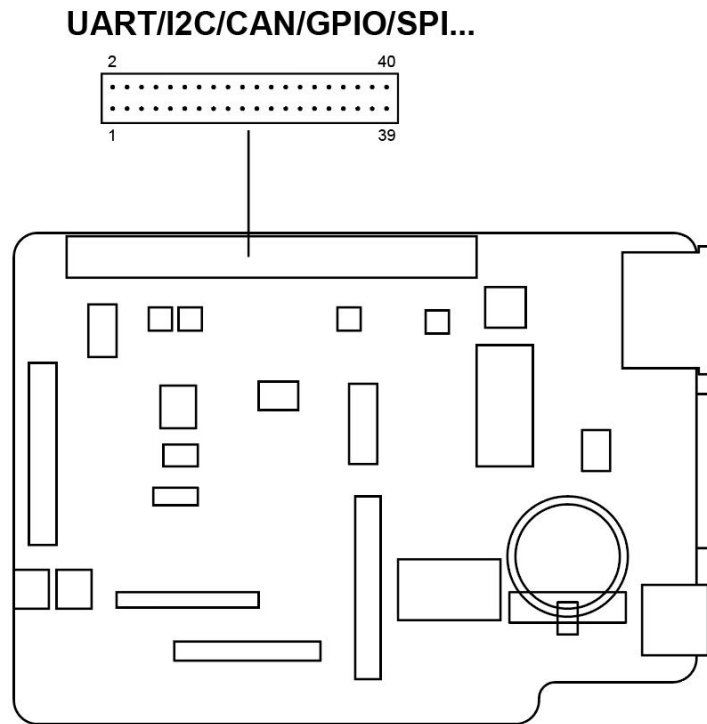

Figure 8 GPIO interface

The GPIO interface pins are defined in the table below; please refer to “DEBIX Model A Reduced GPIO Function List” on the [DEBIX website](#) for pin function mapping definitions.

**Table 6 Pin definition of GPIO**

Pin	Definition	Pin	Definition
1	VDD_3V3	2	VDD_5V
3	I2C4_SDA	4	VDD_5V
5	I2C4_SCL	6	GND
7	GPIO1_IO12	8	UART3-TXD
9	GND	10	UART3-RXD
11	CAN1-TXD	12	I2C6_SDA
13	CAN1-RXD	14	GND
15	ECSPI2_SS0	16	ECSPI2_MOSI
17	VDD_3V3	18	ECSPI2_MISO
19	ECSPI1_MOSI	20	GND
21	ECSPI1_MISO	22	ECSPI2_SCLK

23	ECSPI1_SCLK	24	ECSPI1_SS0
25	GND	26	GPIO1_IO11
27	UART4-TXD	28	UART4-RXD
29	CAN2_RXD	30	GND
31	GPIO5_IO04	32	GPIO1_IO13
33	GPIO5_IO03	34	GND
35	I2C6_SCL	36	UART2-RXD
37	UART2-TXD	38	GPIO3_IO21
39	GND	40	CAN2_TXD

### 2.2.6. MIPI DSI

DEBIX I/O board provides two DSI interfaces:

- DSI to DEBIX (J6), the connector is a 24Pin 0.5mm Pitch FPC socket, which is used to connect to the DSI interface of DEBIX motherboard.
- MIPI DSI (J7), the connector is a 30Pin 1.0mm Pitch FPC socket, which is used to connect to the official Raspberry Pi 7-inch display.

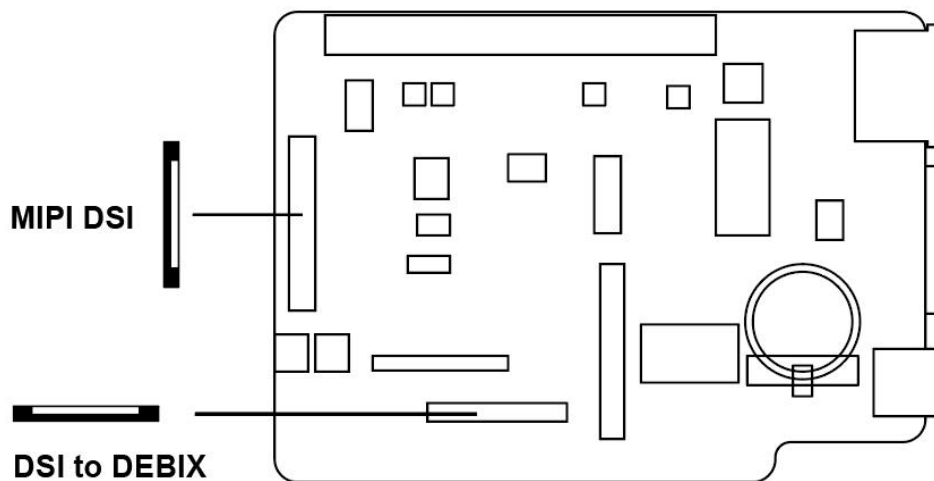

Figure 9 DSI interface



### 2.2.7. MIPI CSI

DEBIX I/O board provides two CSI interfaces:

- CSI to DEBIX (J8), the connector is 24Pin 0.5mm Pitch FPC socket, which is used to connect to the CSI interface of DEBIX motherboard.
- MIPI CSI (J9), the connector is 30Pin 1.0mm Pitch FPC socket, which is used to connect to the Raspberry Pi camera.

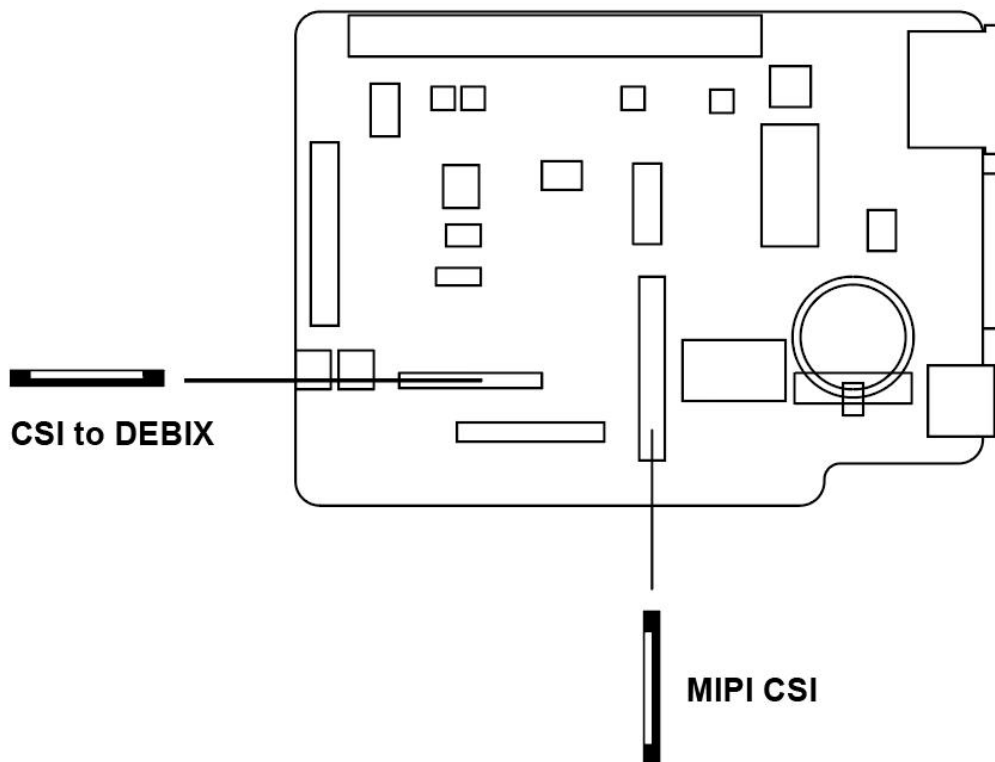

Figure 10 CSI interface

### 2.2.8. DIP Switch

DEBIX I/O board has a total of four DIP switches, each with ON/OFF two states, corresponding to 8 interface types. The DIP switch, which is facing up by default, is in the ON state.

DIP switches make it realizable that DEBIX is able to be compatible with Raspberry Pi 40 pins, if you want to use the function of RS232, RS485, DEBUG, CAN, turn the corresponding switch to the down OFF state.

**Warning**

To protect the DIP switch, the following instructions should be taken care of:

1. The yellow gummed paper should be taken off;
2. Do not use sharp materials to toggle DIP switch.

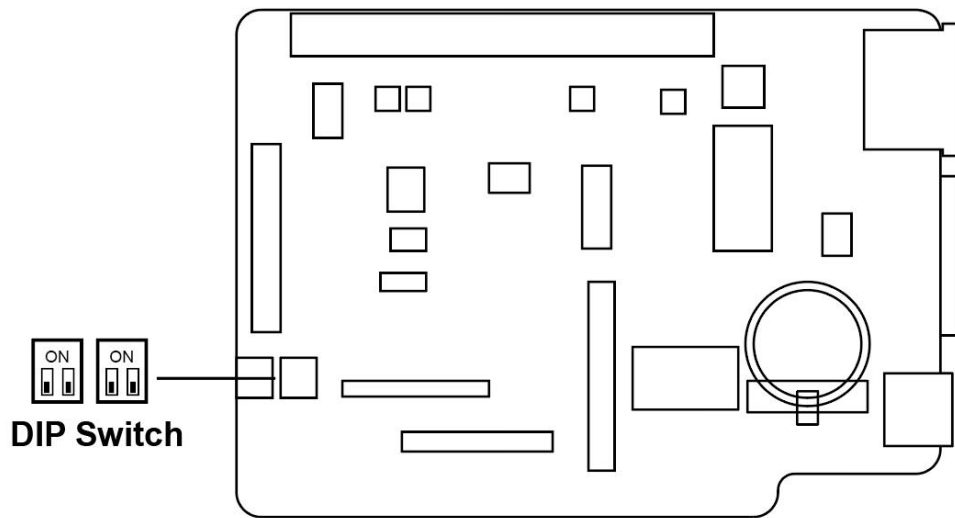

Figure 11 DIP Switch

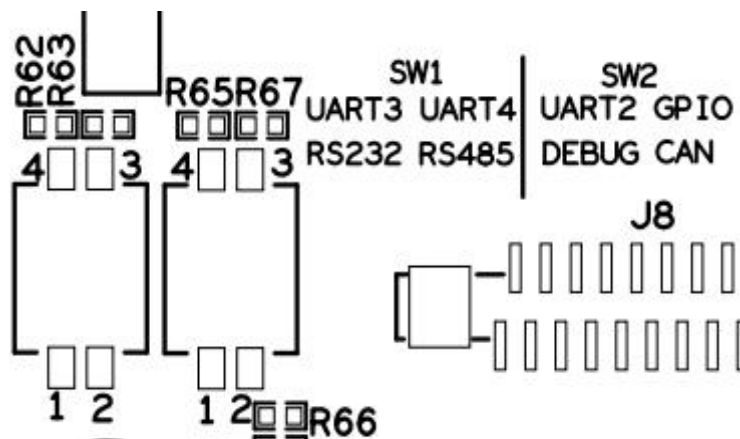

Figure 12 DIP Switch Silkscreen

The left side is SW1, and the right side is SW2, the switches of SW1 and SW2 are set to the corresponding state, and the interface types selected are shown in the table below:

Table 7 DIP Switch Setting Type

Type Switch state	SW1-1	SW1-2	SW2-1	SW2-2
ON	UART3	UART4	UART2	GPIO
OFF	RS232	RS485	DEBUG	CAN

**Note:** switch up stands for ON, switch down stands for OF.

### 2.2.9. RTC

DEBIX I/O board has one RTC interface (J11), which provides precise time reference and improves timeliness for DEBIX system. RTC chip model is HYM8563S, I2C address is 0x51.

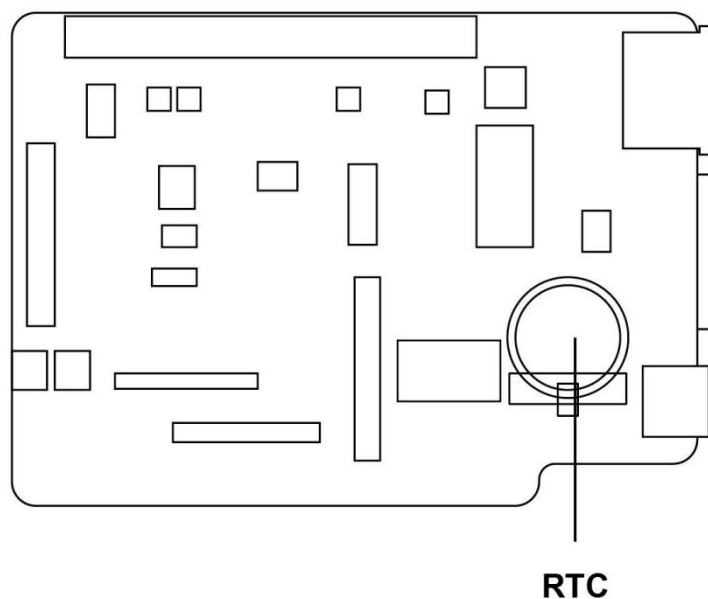

Figure 13 RTC

## 2.3. Packing List

- DEBIX I/O Board
- 2 x FPC cable of DSI & CSI interfaces
- 2 x Ethernet female-to-female DuPont cable

## Chapter 3 Getting Started

### 3.1. Hardware Connection

- **Component Preparation**

- ✓ DEBIX I/O board
- ✓ DEBIX motherboard
- ✓ 1 x DuPont cable (with blue, white double ends)
- ✓ 2 x FPC cable (wide with alphabet)

The connection steps are as follows:

1. Align the female header of the DEBIX I/O Board with the top pin header on the DEBIX motherboard, and press to insert, as shown below:

#### NOTE

It is necessary to confirm that the female header of DEBIX I/O board are aligned one by one with the top pin header on the DEBIX motherboard to avoid damage to the board caused by power on after misalignment.



Figure 14 Female header of DEBIX I/O Board

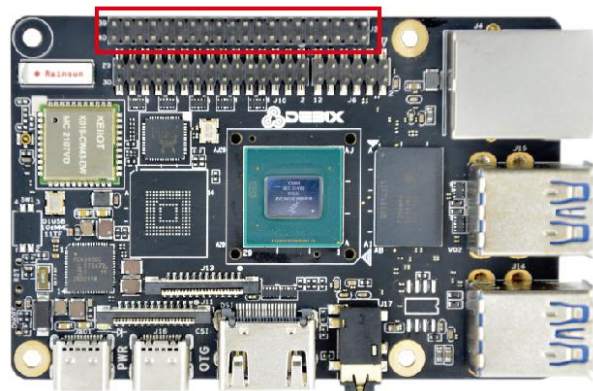

Figure 15 Pin header of DEBIX motherboard

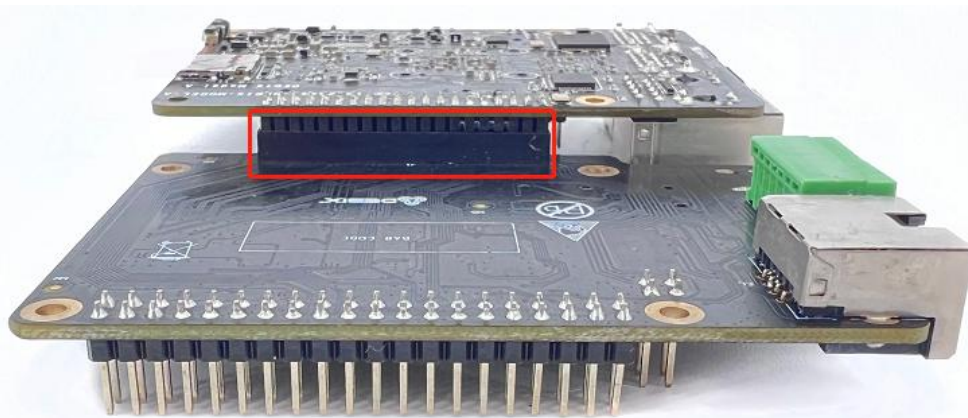

Figure 16 DEBIX I/O Board and DEBIX motherboard are connected

2. Connect the 12pin header network port 1 of DEBIX I/O board to the 12pin header network port 2 of DEBIX motherboard with the DuPont cable shown in the following figure; when connecting, the slots correspond to each other, and no need to distinguish the color of the cable.

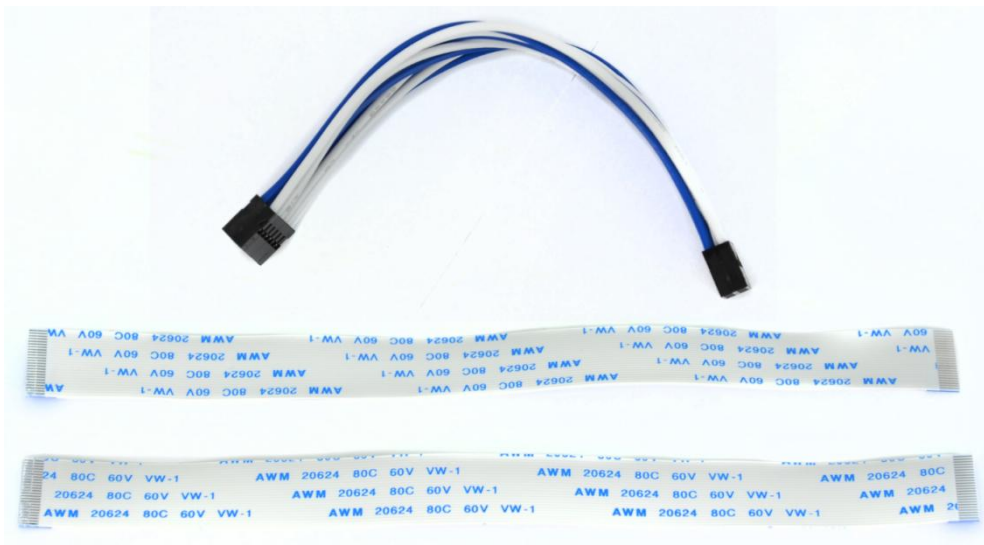

Figure 17 DuPont cable, FPC cable

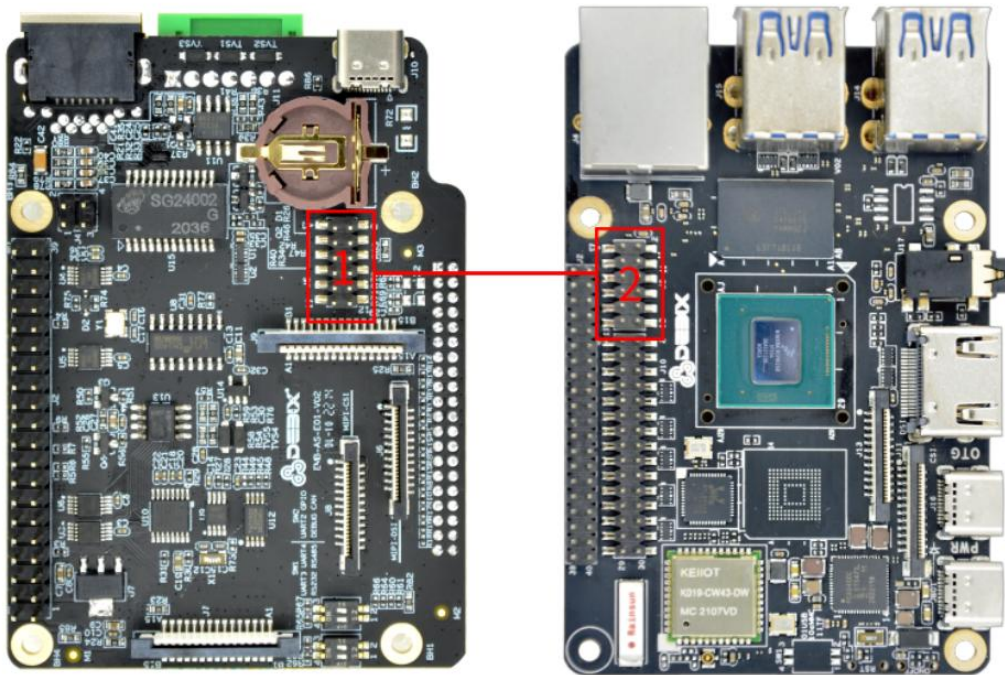

Figure 18 12pin header network port

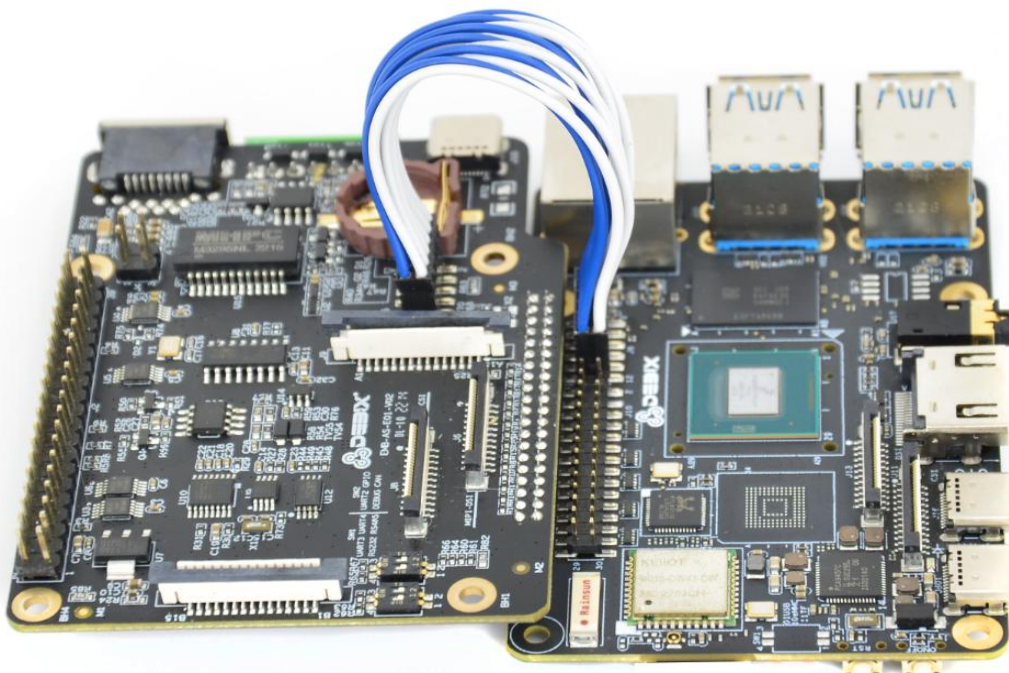

Figure 19 12pin header network port connection

3. Pull up the black plastic snaps of the DSI interface of DEBIX I/O board and DEBIX motherboard, and then connect them with FPC cable, press the snap to fix it after the connection is completed.

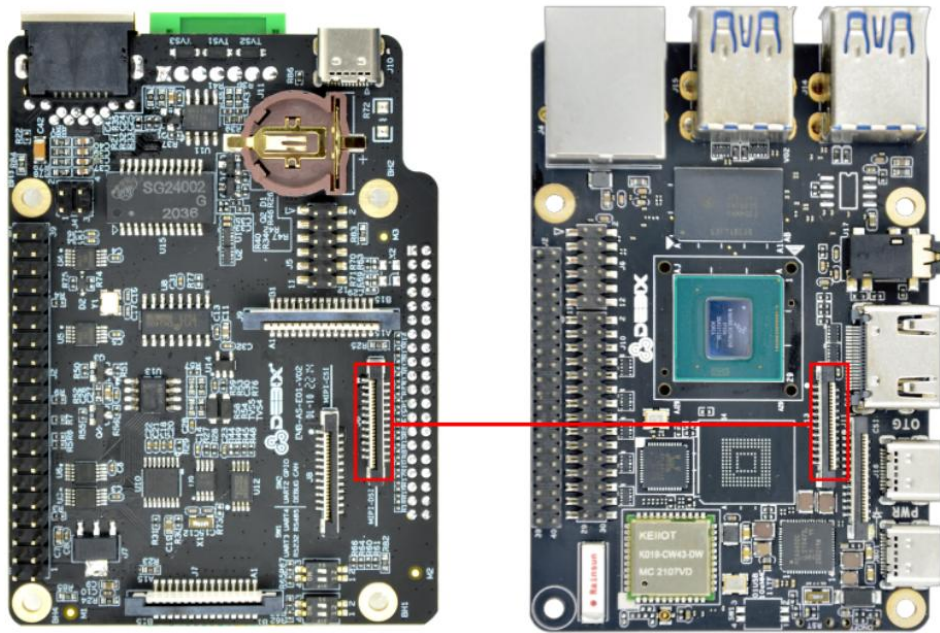

Figure 20 DSI interface

4. Pull up the black plastic snaps of the CSI interface of DEBIX I/O board and DEBIX motherboard, and then connect them with FPC cable, press the snap to fix it after the connection is completed.

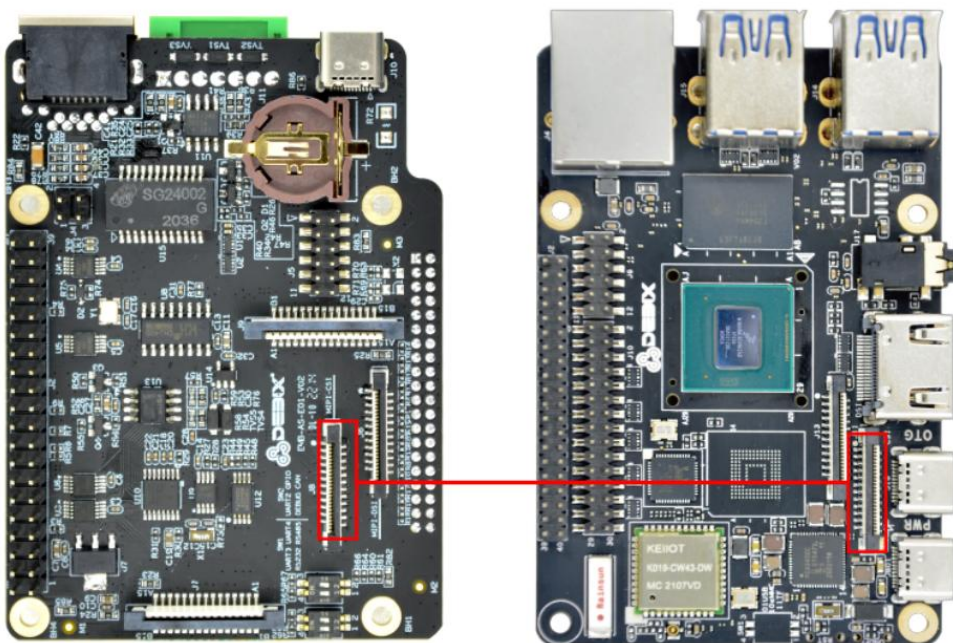

Figure 21 CSI interface

5. The corresponding DSI and CSI interfaces are connected, as shown in the figure below:

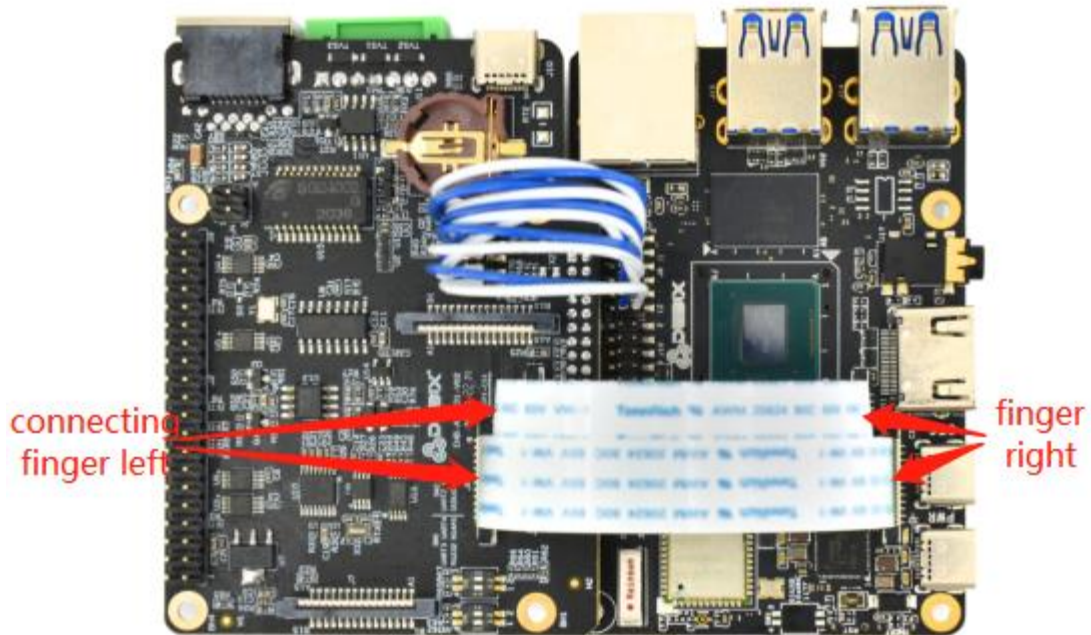

Figure 22

6. Insert Micro SD card with DEBIX system into the slot of DEBIX motherboard, connect DEBIX peripherals (HDMI, keyboard, mouse, etc.), power on, DEBIX can work normally.



## Chapter 4 Function Examples

### 4.1. Ubuntu Desktop Setting

1. Connect DEBIX I/O board and DEBIX as the steps described above, plug the network cable into the MAC Gigabit Ethernet port (ens34) of DEBIX I/O board, and then power up DEBIX;

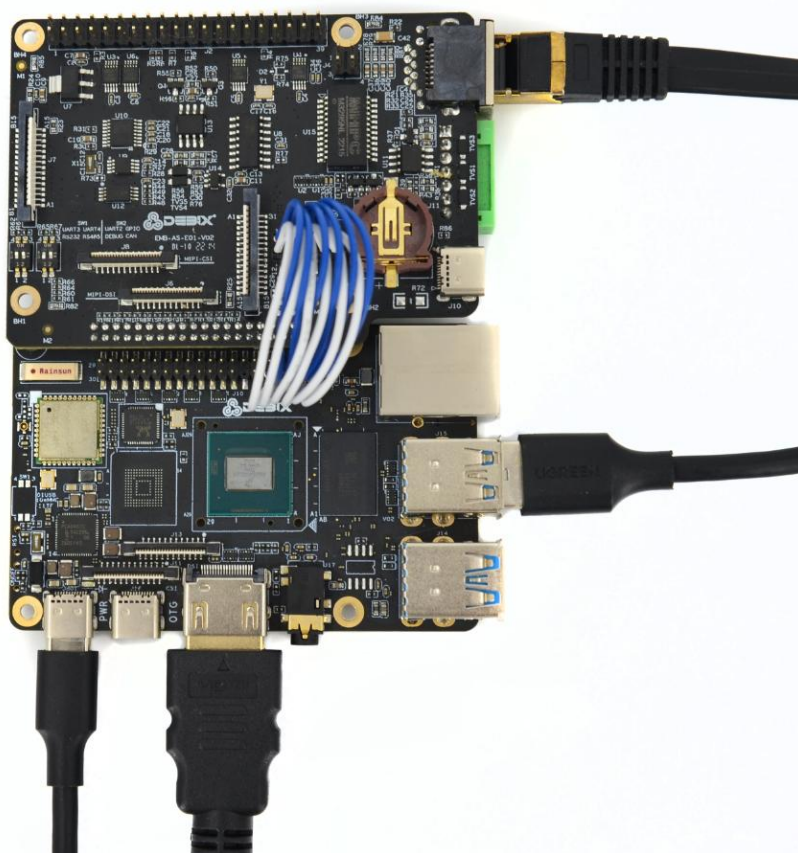

Figure 23 Connect network cable

2. After DEBIX starts up, enter the DEBIX system desktop, select **Add-on Board APP**, and switch to the corresponding device tree;

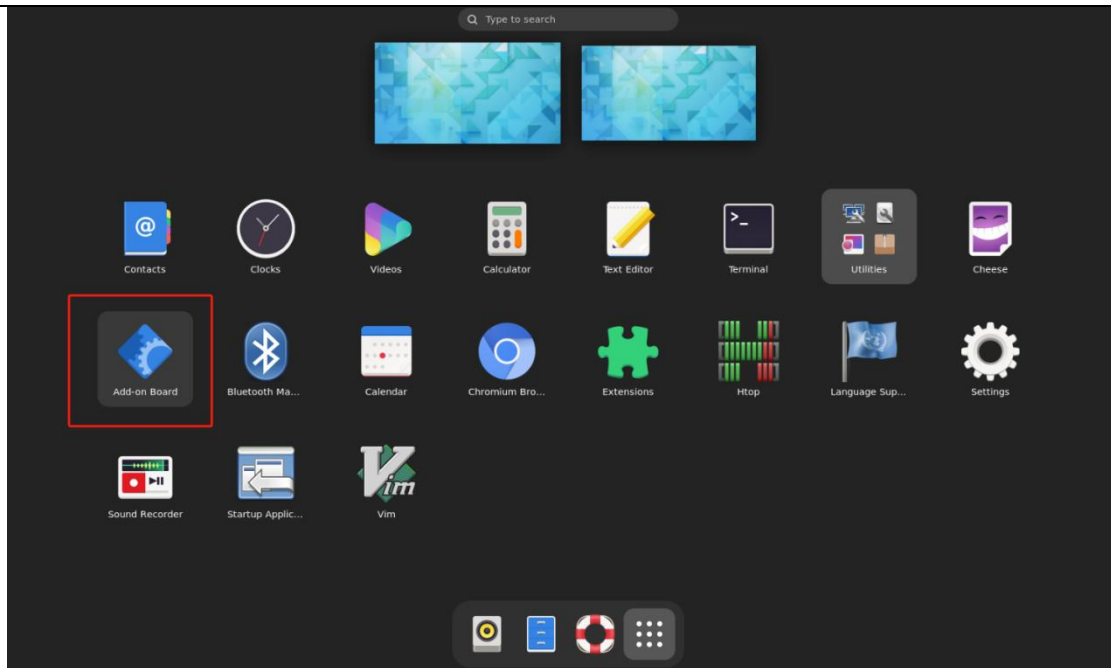

Figure 24

3. In the pop-up "DEBIX add on board dtb file selection" window, select **Debix board** and click **OK**.

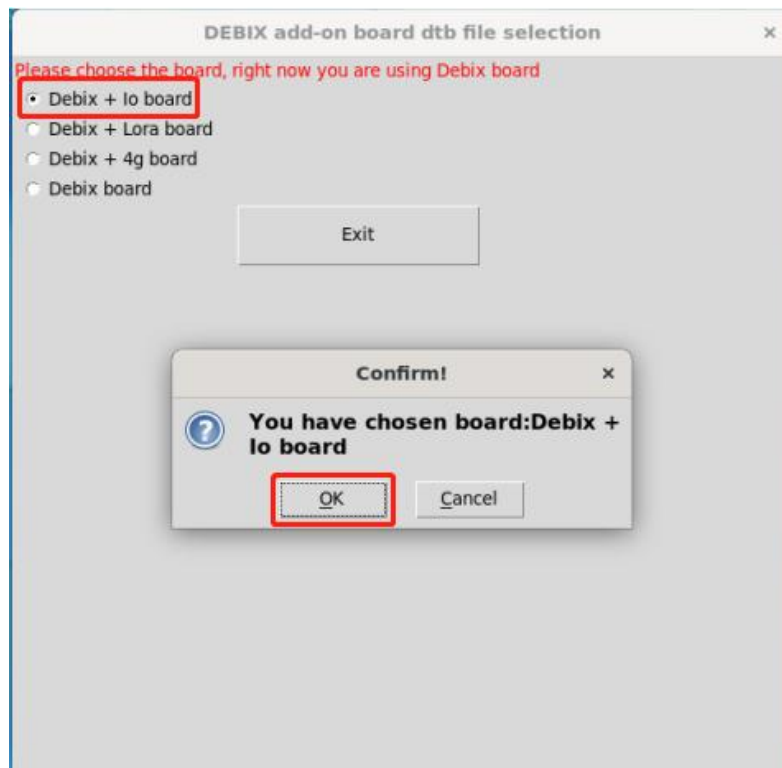

Figure 25

4. Select **None** for Panel and click **OK**.

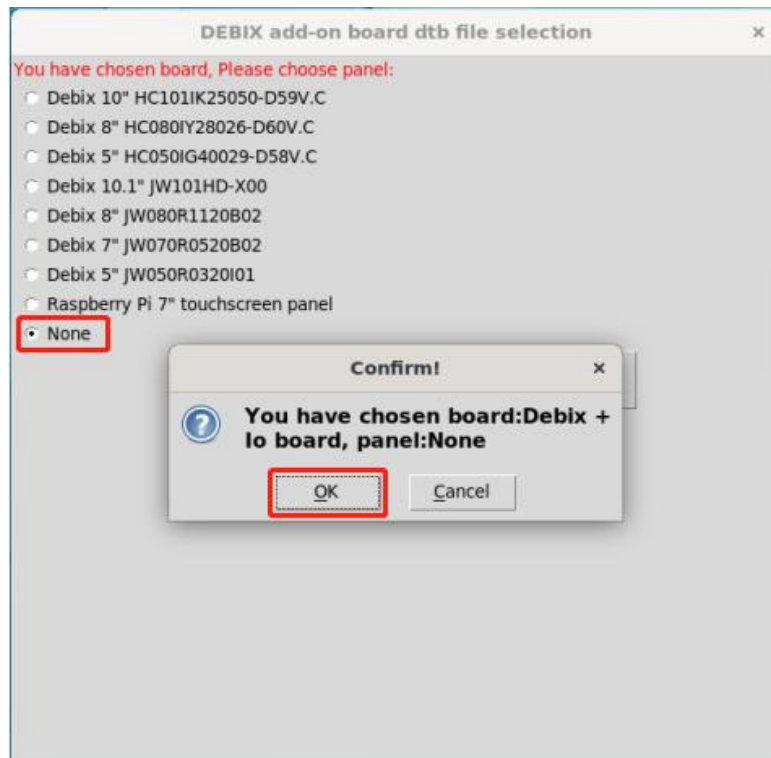

Figure 26

5. Click **Start**, and click **OK**.

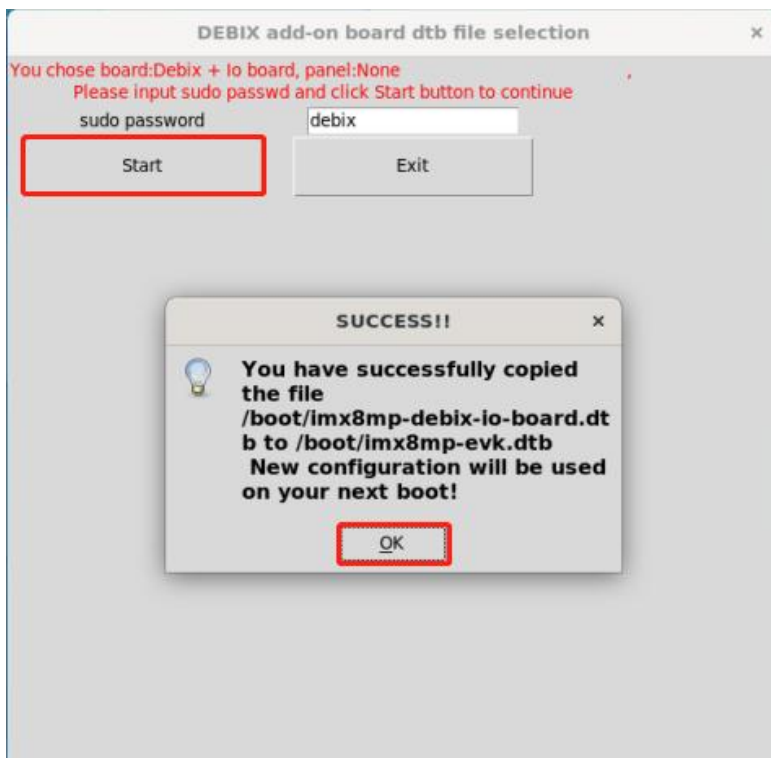

Figure 27

6. Reboot the device to take effect the above settings.

## 4.2. Usage of Ethernet

Open terminal, run command `ifconfig`, query the connected network port.

```
debix@mx8mpevk:~$ ifconfig
ens33: flags=-28669<UP,BROADCAST,MULTICAST,DYNAMIC> mtu 1500
    ether 10:07:23:60:59:ca txqueuelen 1000 (Ethernet)
    RX packets 1666 bytes 136218 (136.2 KB)
    RX errors 0 dropped 0 overruns 0 frame 0
    TX packets 776 bytes 86821 (86.8 KB)
    TX errors 0 dropped 0 overruns 0 carrier 0 collisions 0
    device interrupt 56

ens34: flags=-28605<UP,BROADCAST,RUNNING,MULTICAST,DYNAMIC> mtu 1500
    inet 192.168.2.14 netmask 255.255.255.0 broadcast 192.168.2.255
    inet6 fe80::a5f0:ec78:636c:6700 prefixlen 64 scopeid 0x20<link>
    ether 10:07:23:60:59:cb txqueuelen 1000 (Ethernet)
    RX packets 62 bytes 6282 (6.2 KB)
    RX errors 0 dropped 0 overruns 0 frame 0
    TX packets 55 bytes 8204 (8.2 KB)
    TX errors 0 dropped 0 overruns 0 carrier 0 collisions 0
```

## 4.3. Usage of Type-C Debug

1. Use a USB Type-C cable to connect the Debug port of DEBIX I/O board to Windows PC, as shown in the following figure:

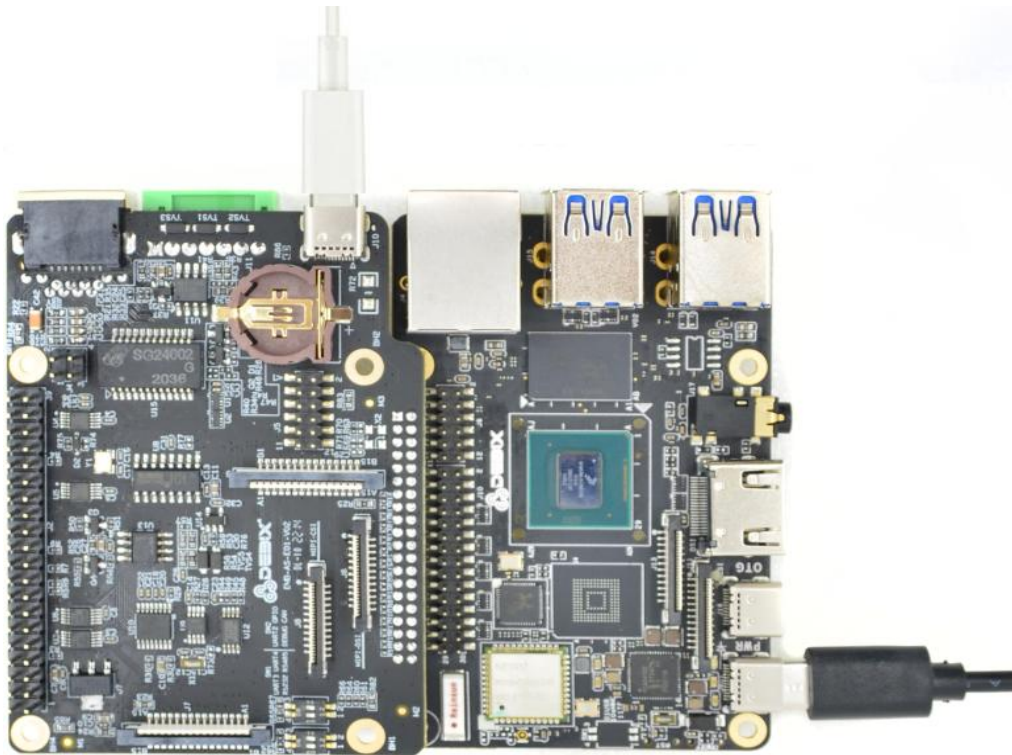

Figure 28 Connect Debug interface to PC

2. Download the [Windows driver](#) for the USB to serial on Windows PC, after the download is completed, as shown in the following figure:

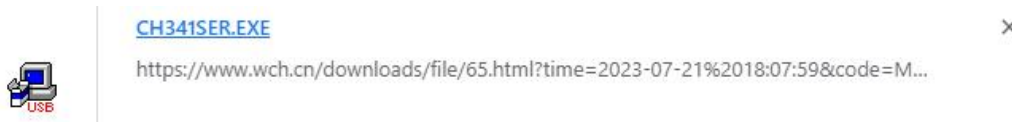

Figure 29

3. Click **Open** --> **Run** --> **Install**, after successful installation, the "The driver is successful Pre-installed in advance!" dialog box will pop up.
4. Right-click "This PC" --> select **Manage** --> select **Device Manager** --> open **Ports (COM & LPT)**, showing "USB-SERIAL CH340 (COM3)", as shown in the figure below:

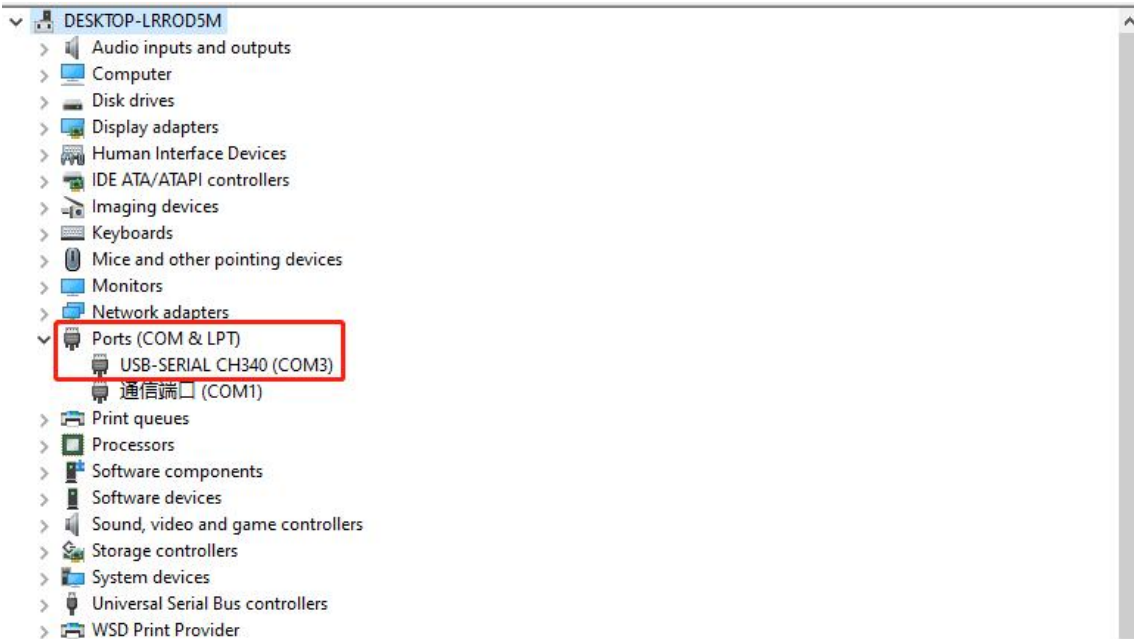

Figure 30

5. Download and install the [putty tool](#);
6. Open putty tool to configure, select **Session**, set **Connection type** to Serial, set the port to **COM3** (keep the same port number as in Device Manager), set **Speed** to 115200, click **Open**.

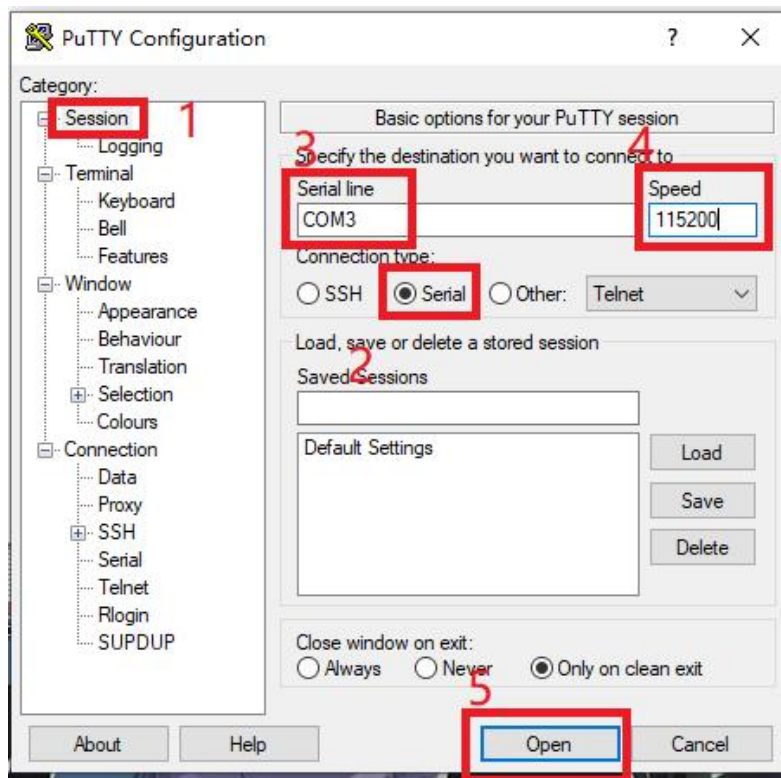

Figure 31 Putty configuration

7. After the serial port is open, type the command to debug.



Figure 32 Putty Serial

## 4.4. Usage of Camera

- **Component Preparation**

- ✓ DEBIX I/O board
- ✓ DEBIX motherboard
- ✓ Raspberry Pi camera, matching 30Pin 1.0mm Pitch FPC cable



Figure 33 Raspberry Pi camera

- ✓ 24Pin 0.5mm Pitch FPC cable

- **Camera Hardware Resources:**

**Table 8 Hardware resources of camera**

Function name	IO name	Description (Device node)
Power control	CSI1_PWDN	
Reset control	CSI1_nRST	
I2C	I2C2_SDA	/dev/i2c-1
	I2C2_SCL	
CSI	CSI1_DN0/CSI1_DP0~	mipi_csi_0
	CSI1_DN3/CSI1_DP3	

● **Hardware Connection**

1. Connect DEBIX I/O board to DEBIX motherboard, and use the 24Pin FPC cable to connect the CSI interfaces of the two single boards;

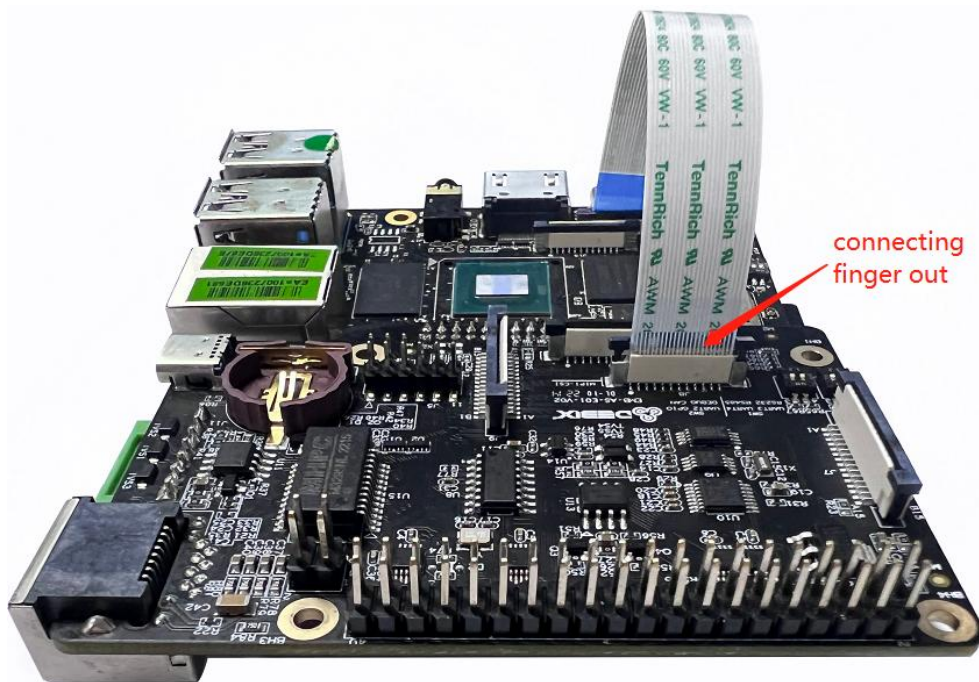

Figure 34 Connect the CSI interfaces

2. Connect the Raspberry Pi camera to the MIPI CSI interface (J9) of DEBIX I/O board with the 30Pin FPC cable;



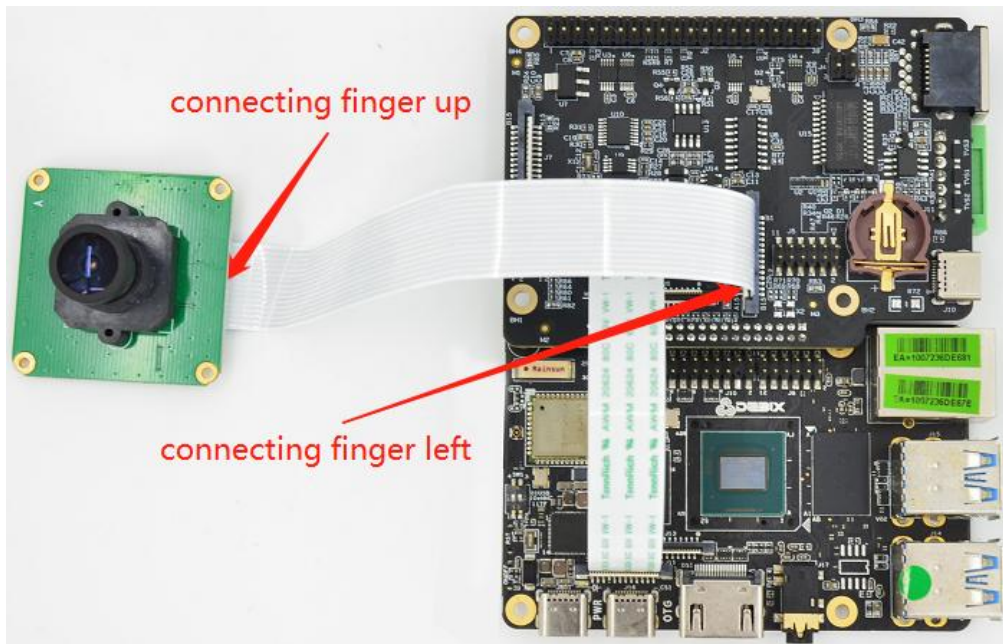



Figure 35 Connect the Raspberry Pi Camera

3. Insert Micro SD card with the latest system into the slot of DEBIX motherboard, connect the DEBIX peripherals (HDMI, keyboard, mouse, network cable), and power up DEBIX.
4. **Verify that the driver is loaded properly:** run the command `lsmod | grep imx219` and print as follows:

```
imx219                28672  1
```

5. Run the command `dmesg | grep imx219` and print as follows:

```
[ 8.789571] imx219: loading out-of-tree module taints kernel.
[ 8.790442] enter imx219_probe
[ 8.790502] enter imx219_power_on
[ 8.846817] imx219_probe camera mipi imx219, is found
[ 9.114965] mx8-img-md: Registered sensor subdevice: imx219 1-0010 (1)
[ 9.114981] mx8-img-md: created link [imx219 1-0010] => [mxc-mipi-csi2.0]
[ 15.574934] mx8-img-md: Registered sensor subdevice: imx219 1-0010 (1)
[ 15.574949] mx8-img-md: created link [imx219 1-0010] => [mxc-mipi-csi2.0]
```

6. Open **Cheese** app  on the desktop and click on  to take a picture, as shown below:

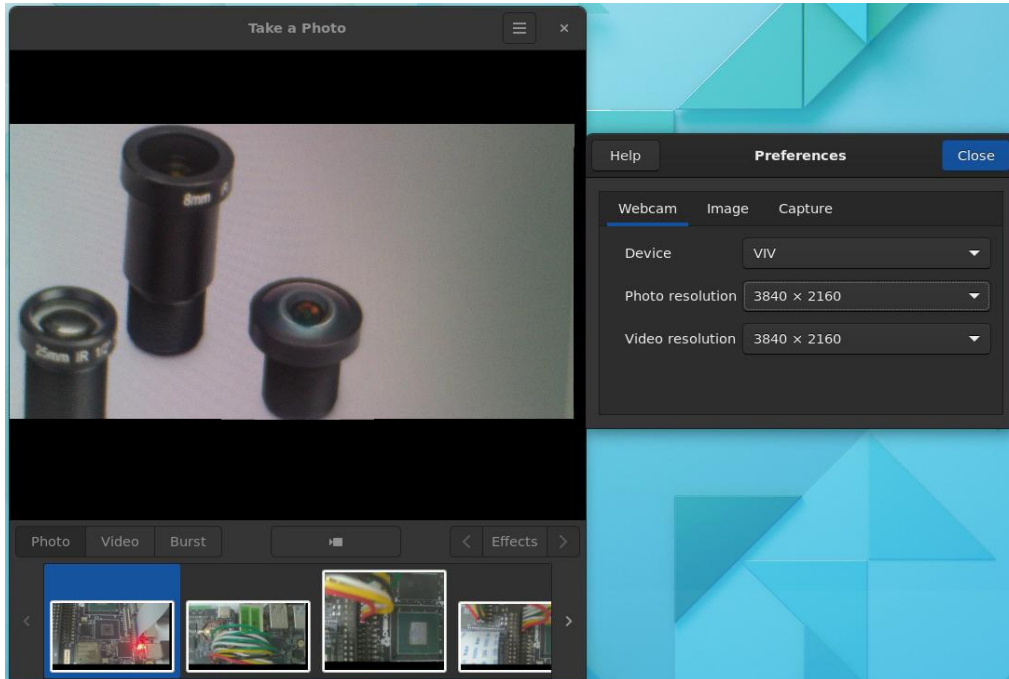



Figure 36

Click the icon  in the upper right corner of the window, select **Preferences** to set the resolution of Photo/Video to take photos or videos.

## 4.5. Usage of DSI Display

### ● Component Preparation

- ✓ DEBIX I/O board
- ✓ DEBIX motherboard
- ✓ Female-to-female DuPont cables, matching DSI cables (30Pin 1.0mm Pitch FPC cable)



Figure 37 Female-to-female DuPont cables



Figure 38 DSI cables

- ✓ 24Pin 0.5mm Pitch FPC cable

- **Hardware Connection**

1. Connect DEBIX I/O board to DEBIX motherboard, and use the 24Pin FPC cable to connect the DSI interfaces of the two single boards;
2. Connect the Raspberry Pi display to the MIPI DSI interface (J7) of DEBIX I/O board with the DSI cable (30Pin FPC cable);
3. Connect the GPIO Pin2 (VDD\_5V) of DEBIX I/O board to the 5V power pin of the display with the DuPont cable (white), and power up the DEBIX to light up the screen.

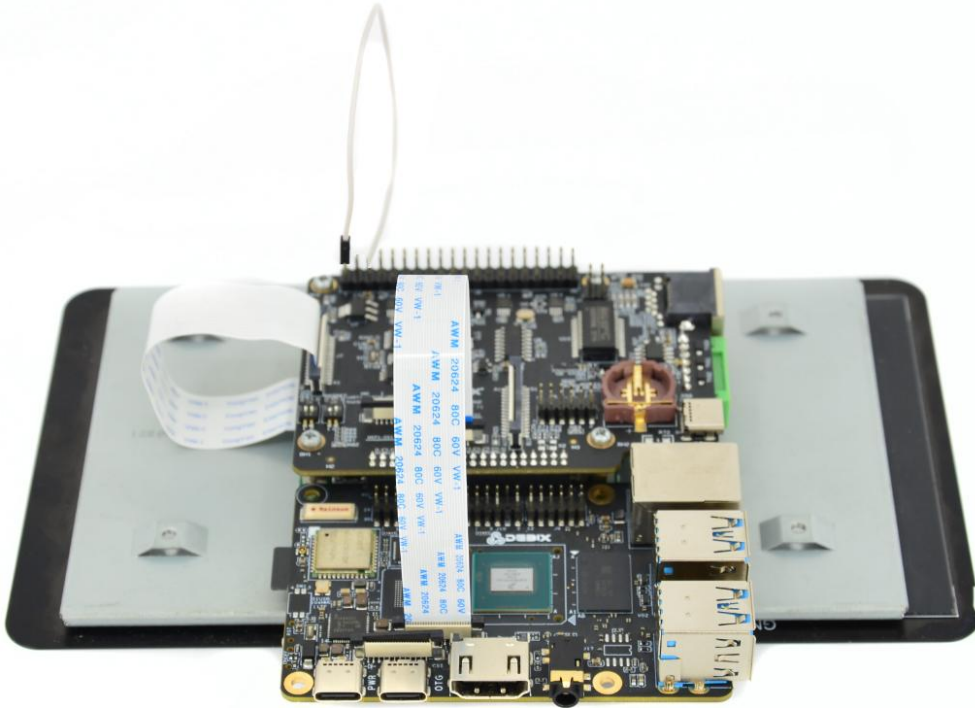

Figure 39



Figure 40

## 4.6. Verification of CAN/RS485/RS232

- **Component Preparation**

- ✓ 2 x DEBIX I/O board, 2 x DEBIX motherboard
- ✓ 2.0 Female-to-female DuPont cables

### 4.5.1. CAN

**CAN connection:**

Connect H to H and L to L of the CAN interfaces of two DEBIX I/O boards, as shown in the table below:

**Table 9 Can interface connection**

Pin	DEBIX I/O board 1	Pin	DEBIX I/O board 2
1	CAN1_H	1	CAN1_H
2	CAN1_L	2	CAN1_L

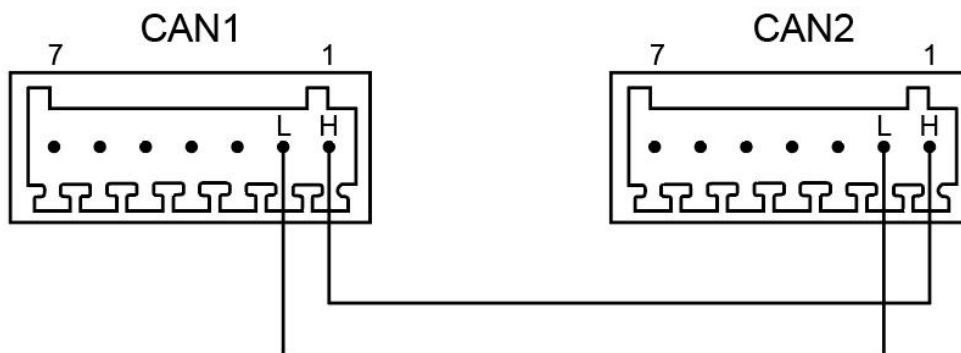

Figure 41

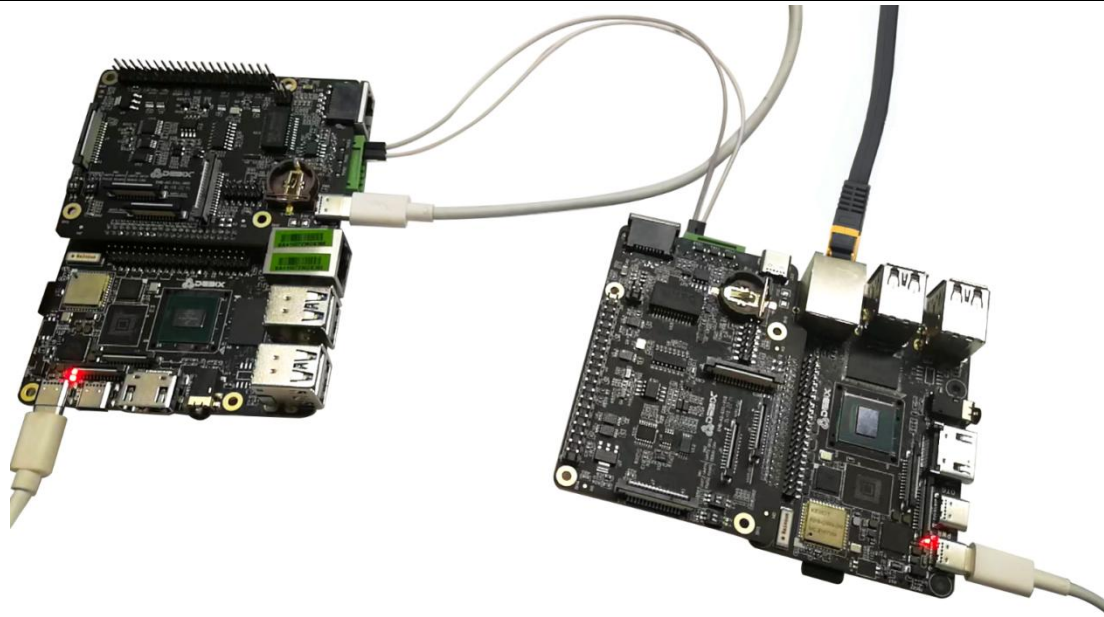

Figure 42 Can interface connection

1. Connect two pieces of DEBIX I/O board + DEBIX motherboard, and set the DIP switch SW2-2 of the two DEBIX I/O boards to OFF.

**NOTE**

CAN function pin multiplexing:

1. When SW2-2 is OFF, CAN1 is connected to Pin1 and Pin2 of the green connector (J12) through the transceiver;
2. When SW2-2 is ON (default), CAN1 is connected to Pin11 and Pin13 of 40Pin GPIO (J2).

2. Power on and test CAN1 communication of two DEBIX:

- Open Terminal window and configure CAN1

```
sudo su
ifconfig can0 down
ip link set can0 type can bitrate 500000
ifconfig can0 up
```

- One CAN1 is configured to send data, and the other is configured to receive data

Receive: candump can0

Send: cansend can0 123#1122334455667788

- When CAN can send and receive the corresponding information (can0 123 [8] 11 22 33 44 55 66 77 88), that is, the communication is successful.

#### 4.5.2. RS485

##### Connection:

Connect A to A and B to B of the RS485 interfaces of two DEBIX I/O boards, as shown in the table below:

**Table 10 RS485 connection**

Pin	DEBIX I/O board 1	Pin	DEBIX I/O board 2
3	RS485_A	3	RS485_A
4	RS485_B	4	RS485_B

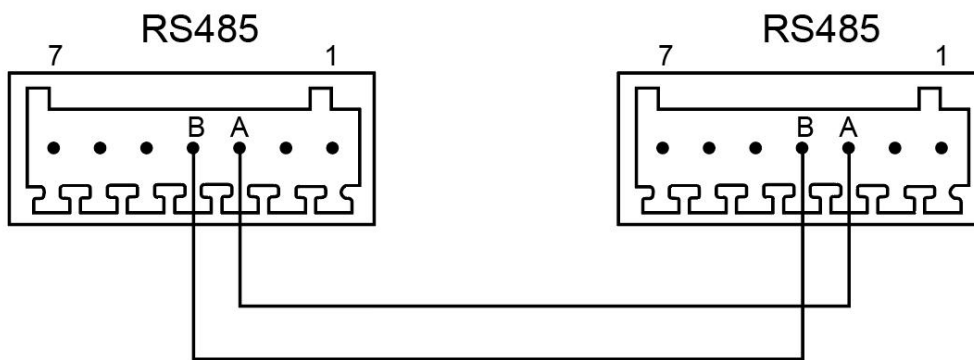

Figure 43

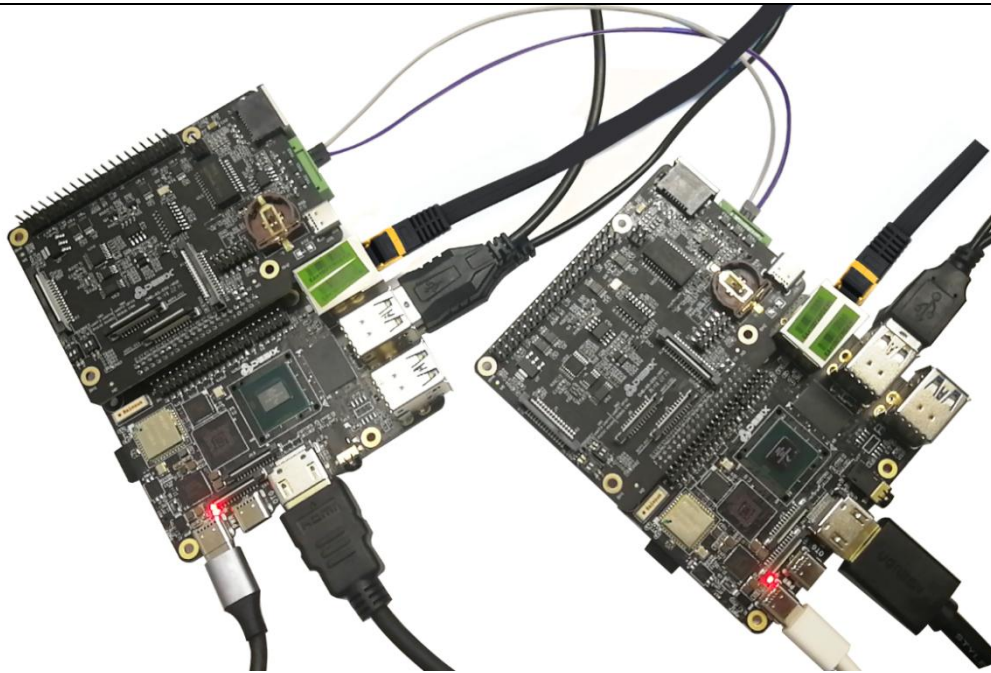

Figure 44 RS485 connection

1. Connect two pieces of DEBIX I/O board + DEBIX motherboard, and set the DIP switch SW1-2 of the two DEBIX I/O boards to OFF.
2. Power on and test RS485 communication of two DEBIX:
  - Open the Terminal on the two DEBIX systems and install the cutecom tool;

```
sudo apt install cutecom
sudo apt install qtwayland5
```

- Run the command `cutecom`, open the cutecom tool;
- Set `Device` to `/dev/ttyMXC3`, and other parameters are set in the following table, click **Open**.

**Table 11 Serial Parameter Settings**

Parameter	Value
Baudrate	115200
Data Bits	8
Stop Bits	1



Parity	None
Flow Control	None

- **Send and receive data through cutecom:** type the test string in the input box of cutecom window, press **Enter** to send, you can receive the same message in the receive box of cutecom window on another DEBIX, which means the communication is successful.

### 4.5.3. RS232

#### Connection:

Connect T to R and R to T of the RS232 interfaces of two DEBIX I/O boards, as shown in the table below:

**Table 12 RS232 connection**

Pin	DEBIX I/O board 1	Pin	DEBIX I/O board 2
5	RS232_RXD3	5	RS232_TXD3
6	RS232_TXD3	6	RS232_RXD3

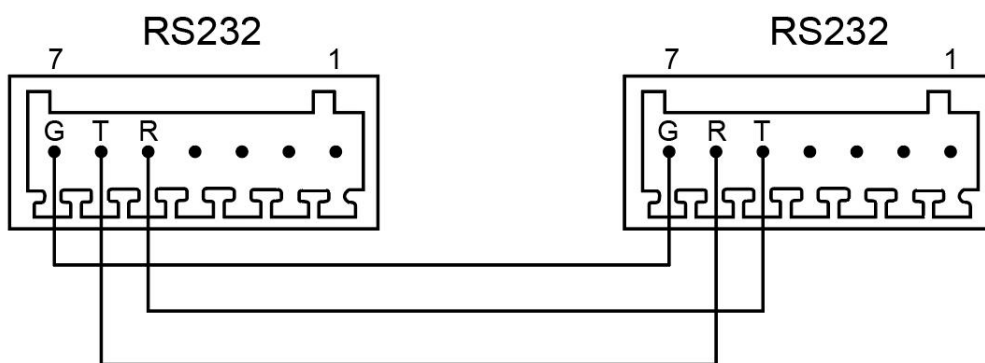

Figure 45

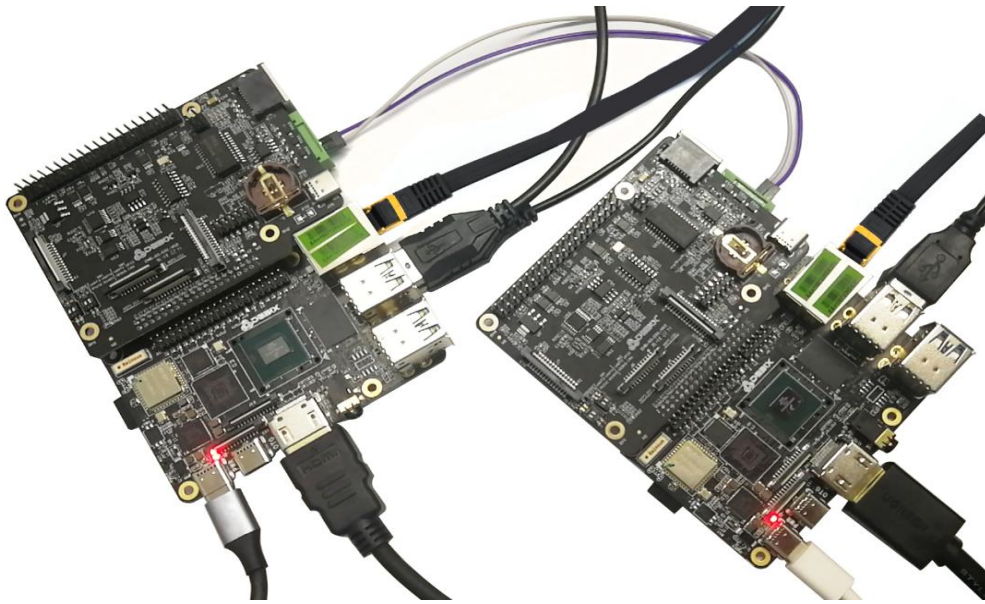

Figure 46 RS232 connection

1. Connect two pieces of DEBIX I/O board + DEBIX motherboard, and set the DIP switch SW1-1 of the two DEBIX I/O boards to OFF.
2. Power on and test RS232 communication of two DEBIX:
  - Run the command `cutecom`, open the cutecom tool;
  - Set `Device` to `/dev/ttyMXC2`, and other parameters are set in the following table, click **Open**.
  - **Send and receive data through cutecom:** type the test string in the input box of cutecom window, press `Enter` to send, you can receive the same message in the receive box of cutecom window on another DEBIX, which means the communication is successful.

## 4.7. Verification of RTC

- **Component Preparation**
  - ✓ DEBIX I/O board, DEBIX motherboard
  - ✓ Peripherals (HDMI, keyboard, mouse, network cable)

- **RTC chip hardware resources:**

Table 13 RTC hardware resource

Function name	I/O name	Device node	Description
I2C	I2C4-SCL	/dev/i2c-3	I2C4 clock
	I2C4-SDA		I2C4 data pin

1. Connect DEBIX I/O board to DEBIX motherboard and connect the peripherals, as shown below:

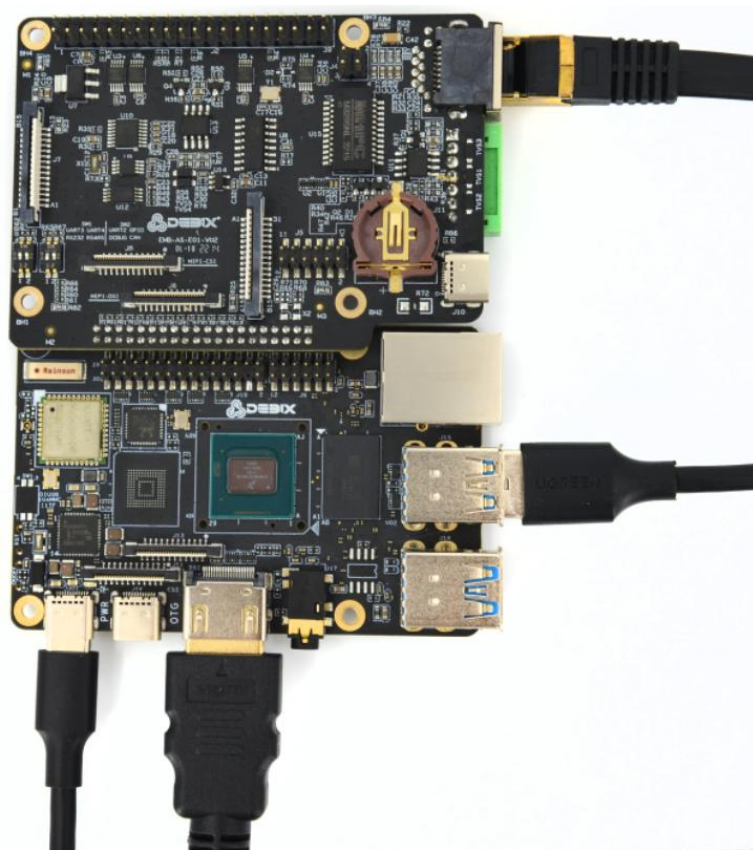

Figure 47 RTC verification

2. **Confirm that the HYM8563S driver module is loaded successfully:** open the terminal, run the command `dmesg | grep rtc-hym8563`, and `printout rtc-hym8563`, which proves that the module is loaded successfully;

```
[ 2.329714] rtc-hym8563 3-0051: registered as rtc1
```

### 3. Set and read the RTC time:

- Read the RTC time, run the command `sudo hwclock -r`.
- Modify the current system time, run the command `sudo date -s "2022-12-08 8:45:00"`.
- Write the system time to RTC, run the command `sudo hwclock -w`.

```
debixaimx8mpevk: . sudo hwclock -w
debix@imx8mpevk:~$ sudo hwclock
2022-12-08 08:46:41 463933+00:00
```

## 4.8. Usage of Raspberry Pi POE HAT

### ● Component Preparation

- ✓ DEBIX I/O board, DEBIX motherboard
- ✓ Raspberry Pi POE HAT
- ✓ Switch or router that supports POE function
- ✓ Micro SD card with DEBIX system, network cable

### ● Hardware connection

1. Connect DEBIX I/O board with DEBIX motherboard;
2. Connect the 40pin and 4pin slots of Raspberry Pi POE HAT to the 40pin and 4pin headers of DEBIX I/O board;

### Warning

When connecting Raspberry Pi POE HAT and DEBIX I/O add-on board, except the 40-pin and 4-pin connection parts, the other components of the two boards should be kept away from each other in case that short circuit occurs.

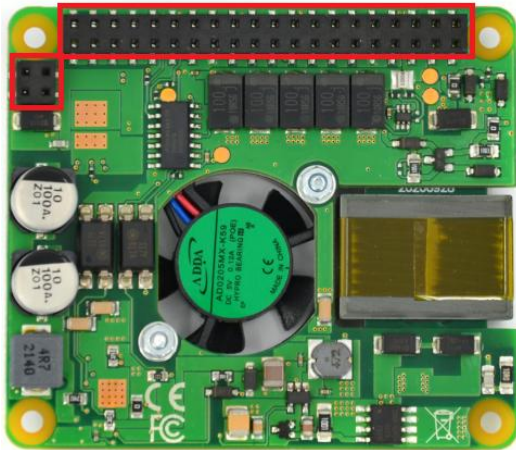

Figure 48 Raspberry Pi POE HAT

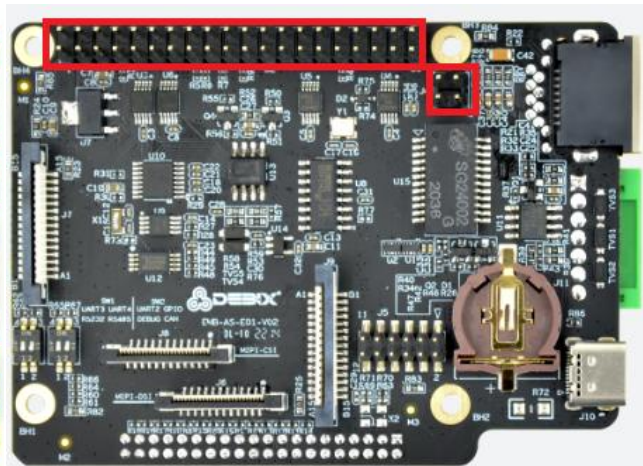

Figure 49 POE interface of DEBIX I/O board

3. Connect the switch (supporting POE) to the 12pin header Gigabit Ethernet port of DEBIX motherboard with a network cable, as shown in the following figure:



Figure 50 Connect switch with DEBIX

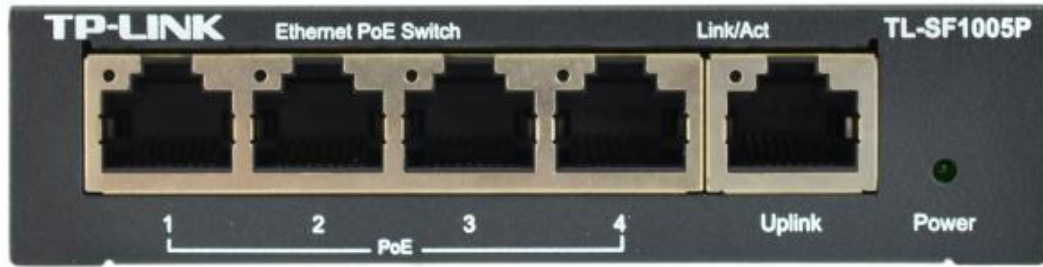

Figure 51 Switch (with POE function)

4. Insert the Micro SD card into the slot of DEBIX motherboard, power on the switch, and the red indicator of DEBIX motherboard will be on, which proves the POE function is normal.

**NOTE**

It is without error that the POE HAT fan does not work, since it is not used.

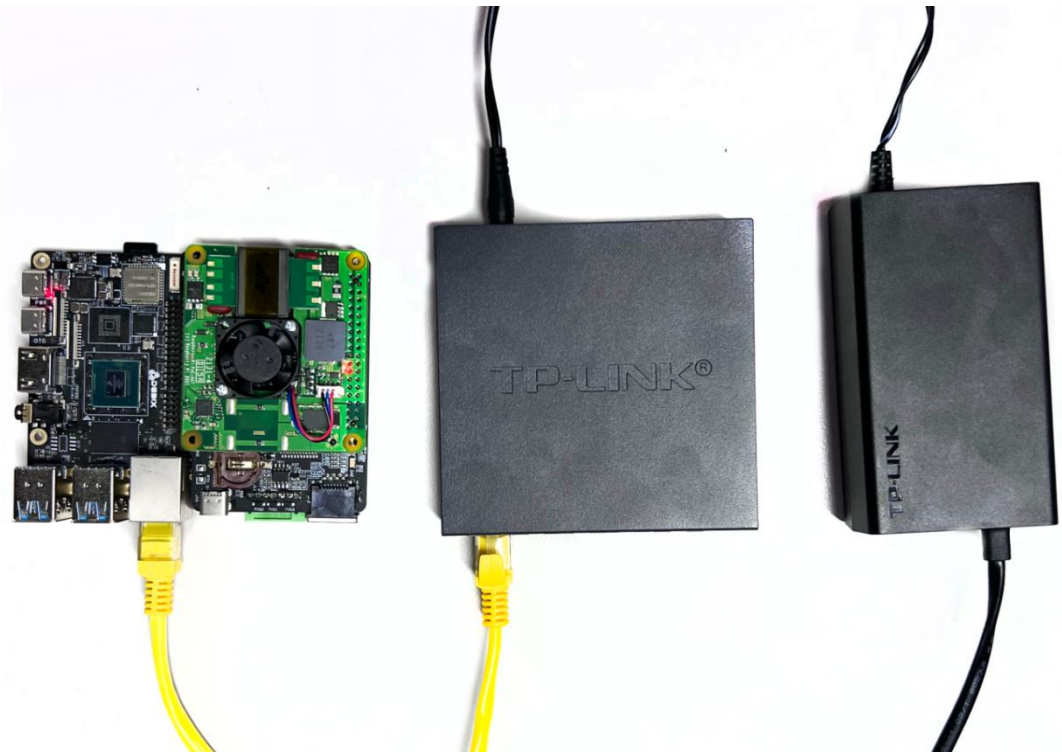

Figure 52 Raspberry Pi POE connection